

**SIEMENS**



[www.siemens.com/plm/femap](http://www.siemens.com/plm/femap)

## Powering today's most advanced engineering analysis environment

Leveraging Femap and its CAD-independent preprocessor and postprocessor  
to facilitate best-in-class finite element analysis

[www.siemens.com/plm](http://www.siemens.com/plm)

# Best-in-class digital simulation

## Why digital simulation?

Industry pressure to reduce costs and improve quality is driving growth in the use of digital simulation throughout the product lifecycle. Choosing the right tools is key to achieving the business benefits of digital simulation.

## Why Siemens PLM Software?

Siemens PLM Software helps manufacturers develop products right the first time with a complete range of simulation, validation and optimization tools.

## Product quality with fewer prototypes

With our digital simulation solutions, companies accurately model and analyze product performance characteristics while minimizing physical prototypes.

Siemens PLM Software's product simulation applications include dynamic motion simulation, basic strength analysis, system-level performance evaluation and advanced response, durability, fluid flow and multi-physics engineering analysis for robust simulation of functional performance.

## Why Femap?

Siemens PLM Software's Femap® system facilitates an advanced engineering analysis environment. CAD-neutral and solver-neutral technology and cost-effective functionality have enabled Femap to become the world's most popular engineering analysis environment for Nastran users. It is widely used by the world's leading engineering organizations and consultants to model complex products, systems and processes, including satellites, aircraft, defense, automotive vehicles, electronics, heavy construction equipment, lift cranes, marine vessels and process equipment.

Femap and NX™ Nastran® software are highly integrated and can be sold together as a bundled solution. But more than this, being open to all solvers, Femap demonstrates the power and value as a core analysis tool.

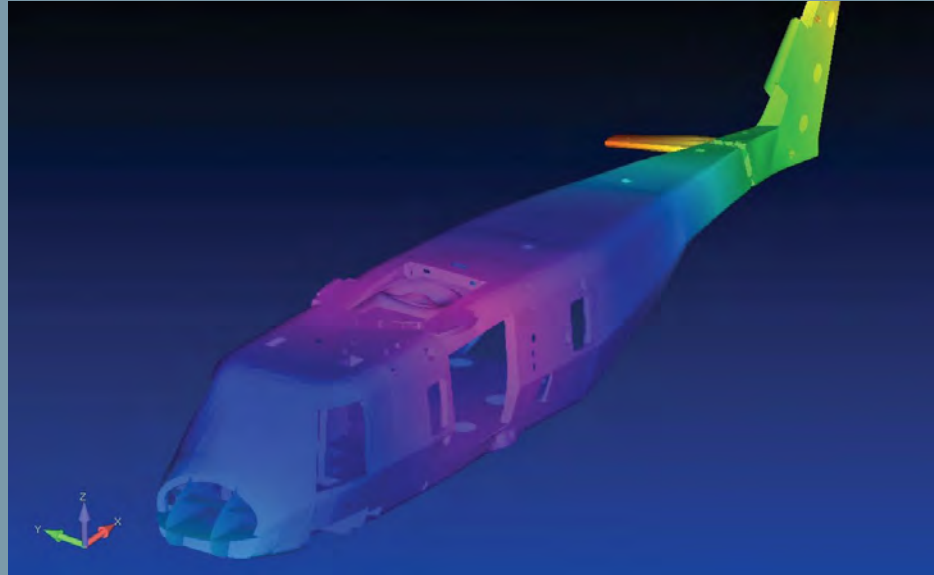

Femap is CAD independent and leverages Siemens PLM Software's Parasolid® modeling kernel that allows direct access to Parasolid data for surface and solid modeling in addition to advanced geometric tools necessary for accessing non-Parasolid geometry.

From advanced beam modeling, mid-surface extraction and hex meshing to robust CAD import and idealization, Femap gives you unparalleled model control and flexibility with a broad range of loads, materials, analysis types and visualization options.

Femap is not just a solid investment for those committed to excellence in the use of finite element analysis technologies. It's the right tool to help you realize your business goals.

## Your business benefits

- Faster to market with innovative new products
- Lower cost through less physical prototyping, fewer engineering change orders and better in-service warranty
- Increased product quality

# FEA performance with ease-of-use

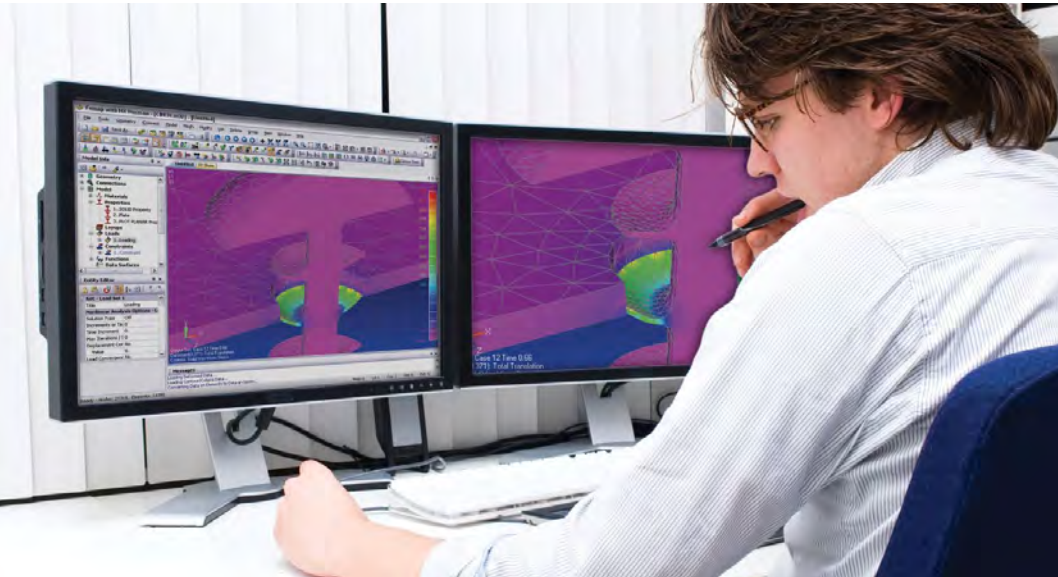

Inside front cover:  
Courtesy of Eurocopter  
Germany GmbH

Page 3: The modern Windows-native user interface provides a flexible and customizable analysis environment for structural, thermal, CFD and in-house applications.

Femap is recognized as the world's leading CAD-independent Windows-native pre- and post-processor for advanced engineering finite element analysis (FEA). It provides engineers and analysts with an FEA modeling solution to handle even the most complex tasks easily, accurately and affordably.

Femap has embodied the principles of power and simplicity for over 20 years and continues that focus today with a Windows-native graphical user interface and efficient workflows that simplify access to all Femap functionality and streamline the process of creating an accurate and representative simulation model.

**As an engineer, you demand software that is not only cost effective and easy to use, but with the power to model the toughest problem. Femap delivers just that – affordable high-performance FEA modeling for the engineering desktop with Windows-native ease-of-use.**

Benefits of Femap Windows-native user interface include the ability to:

- Work with multiple analysis models in the same session, using multiple views per model
- “Cut and paste” from one model to another
- Easily access modeling data, assembly management and analysis setup with the Model Info tree
- Review and edit Femap model data with the entity editor, as well as copying and pasting information between Windows applications
- Easily sort, group and edit results data using the convenient grid-based tabular representation of the Data Table
- Select Femap entities from the top level of the interface using the fully customizable toolbar interface
- Leverage the value of a common Windows-native implementation with fully customizable floating dockable toolbars

Femap features a complete set of fully customizable, floating dockable toolbars.

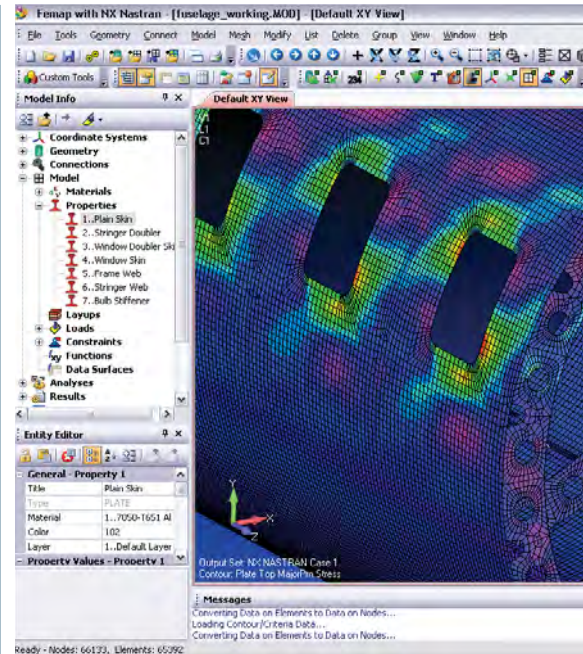
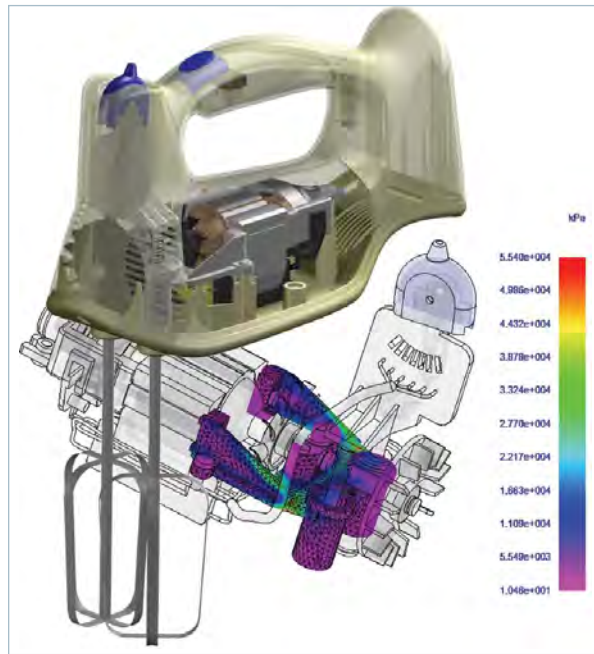

## Scalable solutions

### Powerful, affordable CAE

Femap is available inside Solid Edge® software, standalone and bundled with NX Nastran with add-on modules that form a series of powerful, robust and affordable solutions suitable for companies that have a diverse set of analysis requirements. By providing engineering and design teams with advanced CAE tools, companies enable their engineers to focus on improving product performance and reliability while streamlining the product development process.

### Solid Edge Simulation

Solid Edge Simulation is a CAD-embedded simulation solution for the Solid Edge mainstream 3D CAD system that provides a guided approach to the analysis of solid and sheet metal components and assemblies. Solid Edge Simulation

harnesses Femap modeling expertise with the time-tested and proven NX Nastran solver technology. With Solid Edge Simulation, design engineers will be able quickly and easily determine whether the component or assembly under design will meet strength, vibration or buckling requirements – all within the Solid Edge environment. Solid Edge also provides synchronous technology with CAD model associativity to speed up any necessary model refinement and update after the analysis.

### Femap with NX Nastran

The Femap with NX Nastran package seamlessly combines the advanced functionality of the Windows-native Femap pre- and post-processor with the powerful NX Nastran solver. Femap with NX Nastran allows engineers access to a much greater depth of analysis functionality to easily and efficiently solve complex engineering problems.

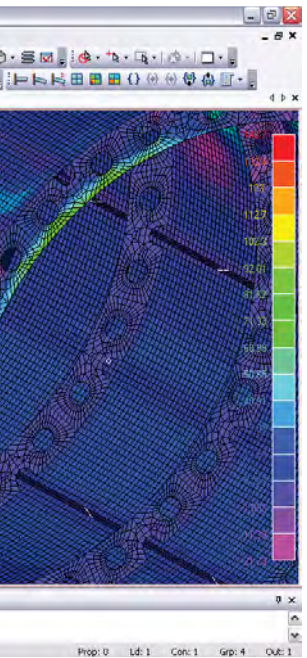

### Additional NX Nastran modules

A series of advanced NX Nastran solution capabilities are available as add-on modules, providing engineering desktop solutions for even the most advanced Nastran analysis.

### Proven solutions

By leveraging over 25 years of integration effort, Femap with NX Nastran provides direct access right on the Windows engineering desktop to the most complete suite of Nastran capabilities available today. Siemens PLM Software combines flexible licensing and packaging with “fair value” pricing to provide all engineering tool users with an affordable way to access the most advanced Nastran capabilities at an attractive total cost of ownership.

*“Creating advanced models that are both accurate and fast definitely gives us a competitive edge and has become a critically important contribution on these fast-paced, technically challenging spacecraft projects.”*

*Jeff Preble  
SpaceWorks*

Display multiple views of the same Femap model and/or multiple models in the same work session.

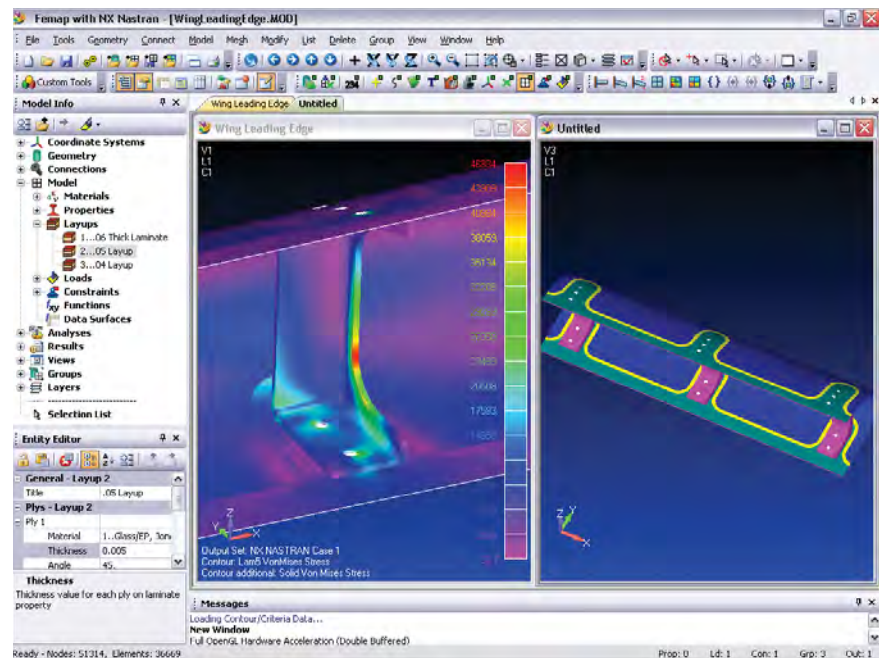

## CAD independent

### Serious engineering in a Windows environment

Femap delivers a depth of functionality normally only found in more expensive applications. With powerful tools easing all aspects of the creation, manipulation and review of an engineering analysis model, Femap is the natural choice for a complete CAD-independent analysis environment.

Femap provides exceptional value and performance and is not limited to geometry-based digital data. Femap will also delight customers working with pure finite element model data. As a nuts-and-bolts, “bottom up” finite element pre- and post-processing solution, Femap provides a range of FEA model readers to rapidly import existing models from many FEA solvers. Advanced functionality then eases manipulation of finite element data at the node and element level.

The bottom line is that Femap makes it possible to quickly create models that accurately predict the structural, dynamic and thermal performance of single components, assemblies or complex systems.

### CAD independent

Femap offers seamless geometry access with major CAD systems such as Pro/Engineer, Catia, NX, NX I-deas® software, Solid Edge, AutoCAD and SolidWorks. Based on the industry-standard Parasolid geometry engine, Femap offers extensive geometry creation tools including standard wireframe curves, surface and solid modeling. Powerful shelling, blending, Boolean operations, surface imprinting and lofting combine to make Femap extremely effective at creating geometry for analysis.

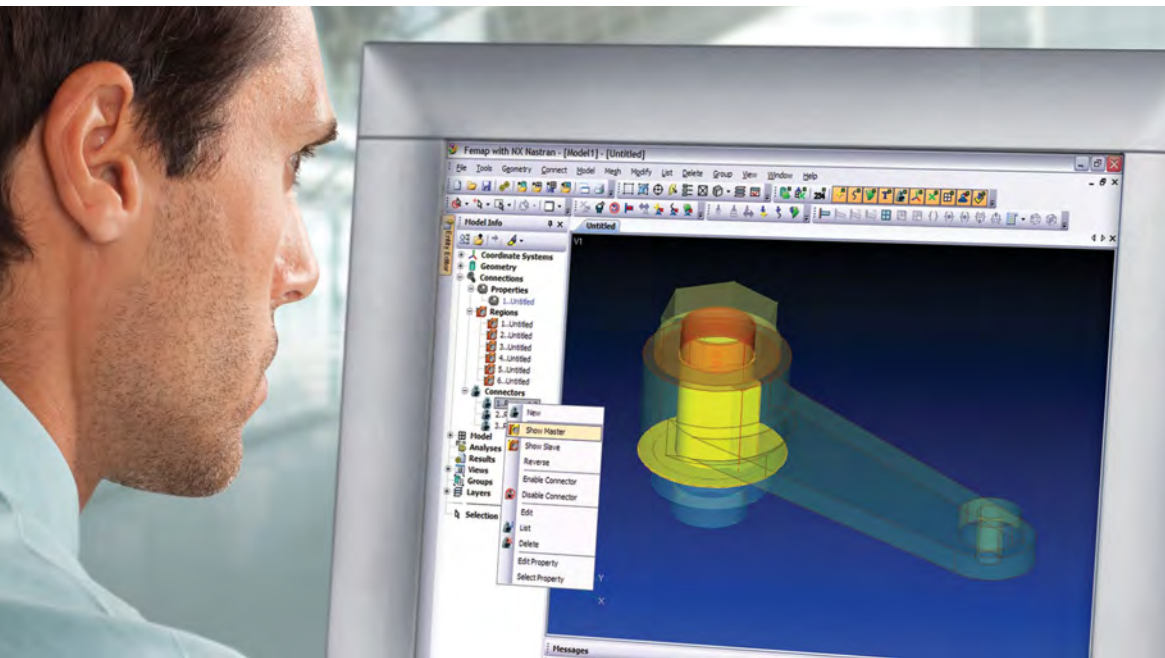

Assembly model

### A better mesh, faster than ever

With fully automatic, high-speed tetrahedral solid meshing and quad-dominant surface meshing technology, Femap creates fast and accurate meshes easily and reliably. You can also take over full control and work interactively with Femap to manipulate the mesh or underlying geometry, while viewing element quality feedback live.

### The right geometry for analysis

Engineers often encounter geometry that is not ideal for analysis model definition. Femap provides geometry creation and editing tools for curves, surfaces and solids, feature suppression and mid-surface extraction. Solids can be subdivided and automatically connected to represent dissimilar materials for semi-automatic hexahedral mesh generation. Engineers can combine multiple surfaces to improve meshing areas for higher quality shell meshes.

### Automatic assembly management

Femap can automatically detect components of an assembly that are in contact. The method of connection, whether glued or contact (linear and nonlinear) is easily specified allowing rapid setup for assembly models.

*“The significant meshing enhancements for hexa-elements in Femap helped our productivity to increase by 30 percent or more. Even for difficult shapes, Femap performs well. Without requiring a complicated operation, a good quality mesh can be obtained.”*

*Yuka Fukunaga  
Analysis Technology Research Center  
Sumitomo Electric Industries*

Courtesy of  
Cideon Engineering  
GmbH

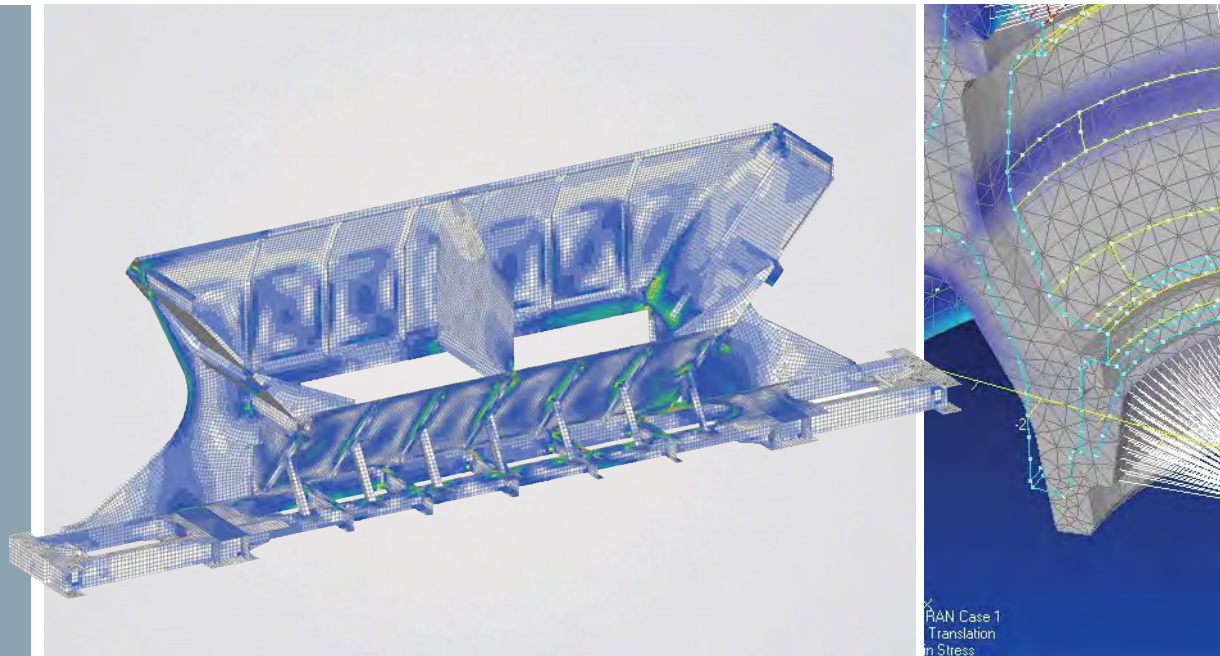

## Solver independent

### Integrating analysis technologies

Leading firms recognize that a single analysis technology seldom meets all their requirements. By integrating multiple analysis technologies in a single modeling and visualization environment with Femap, they can make better design decisions faster.

### Analysis set manager

The analysis set manager in Femap allows you to store solver setup data with your models, so you don't need to complete numerous dialog boxes each time you edit your model and create a new analysis input file. The sets can also be saved in a library for use with other models.

### Multiple solver support

Femap provides in-depth, high-quality support for industry standard solvers, including the popular and proven NX Nastran, MSC/MD Nastran, Abaqus, Ansys, MSC. Marc, LS-DYNA, SINDA and TMG. Femap provides the ability to re-use and integrate analysis models from legacy data as

well as from customers and suppliers. The complete Femap element library, with comprehensive support of physical and material definitions, takes full advantage of the advanced capabilities of these solvers, including dynamic, geometric and material nonlinear, heat transfer and fluid flow applications.

Leading third-party solution providers use Femap to perform CFD, soil modeling, advanced thermal analysis and electromagnetic simulations.

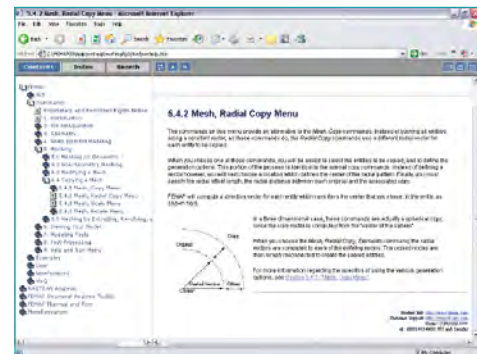

Easy-to-use online HTML and PDF documentation and help

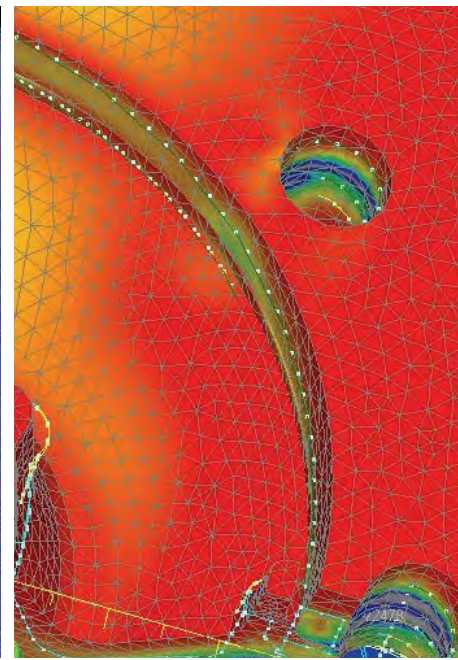
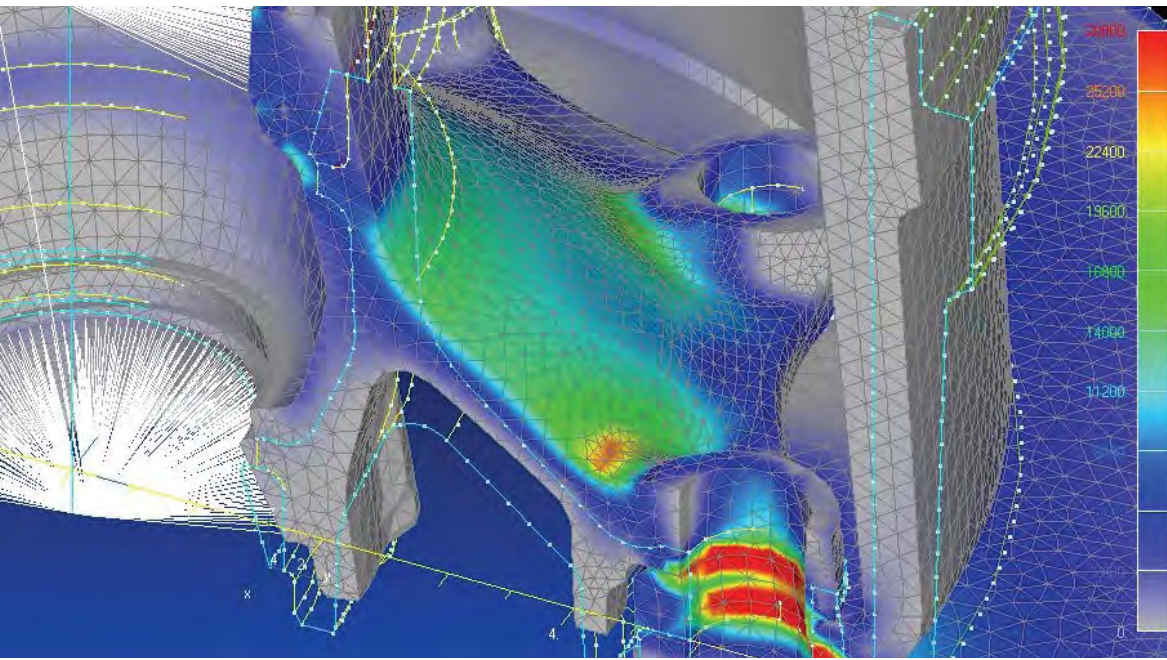

Photos courtesy of KIC Holdings Inc.

## Fully customizable

### Integrated BASIC API Programming Environment

Femap offers a full-featured BASIC development environment in a separate window. Directly from the Femap user interface, you can access the OLE/COM object-oriented Femap application programming interface (API) that provides direct access to all Femap objects and functionality. The BASIC engine is fully OLE/COM compliant and can interface with Femap as well as any OLE/COM compliant program such as Word or Excel. You can create custom programs that automate repetitive tasks, search model or results data, or programs that transfer model information to Word or Excel to create customized reports.

Many useful programs are delivered with Femap in an ever expanding library, and can be found in the Custom Tools toolbar right in the user interface.

These powerful customization capabilities allow complete access to Femap full functionality through standard nonproprietary programming languages, and maintain Femap as the industry's premier independent and open engineering environment.

### Macro program files

In addition to the API programming capability, Femap hosts a Program File capability in its own Femap window. User-defined macros can be recorded, edited, debugged, and played back all within the Femap interface. For example, macros to automate repetitive modeling tasks can be created in an easy and straightforward manner. Once created, you can add these macros to any Femap toolbar, providing powerful automation tools that are easy to produce, deploy and use.

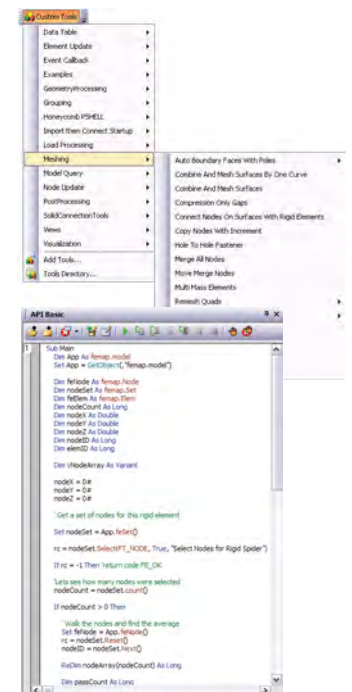

# Flexible solution configurations



<<< **Femap with NX Nastran**  
Provides all of the capabilities that you will need in many instances, including linear statics, normal modes, buckling, steady-state and transient heat transfer, basic nonlinear, design sensitivity and unlimited problem size capabilities.

**Dynamic response** >>>  
Enables product performance to be evaluated in both the time and frequency domains.

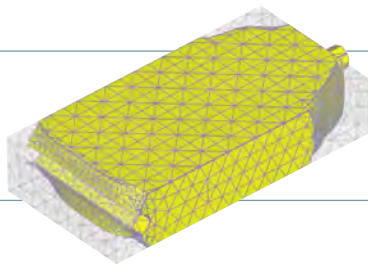

<<< **Optimization**  
Determine optimal design parameters with topology and sizing optimization capabilities.

**Rotor dynamics** >>>  
Predicts the dynamic response of rotating systems such as shafts, turbines, and propellers to determine critical shaft speeds.

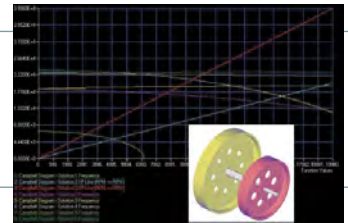

<<< **Advanced nonlinear**  
Facilitates large deformation; supports nonlinear materials, time-dependent loads, deformable and rigid contact. Provides nonlinear time integration for impact analysis.

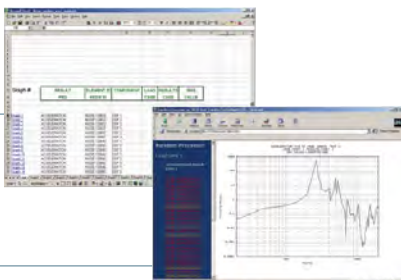
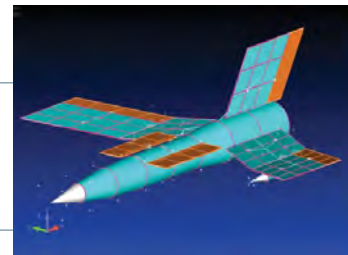

**Aeroelasticity** >>>  
Determine structural response from aerodynamic loading for static and flutter conditions.

<<< **Structural analysis toolkit**  
Saves postprocessing time by organizing results data and calculating additional results quantities.

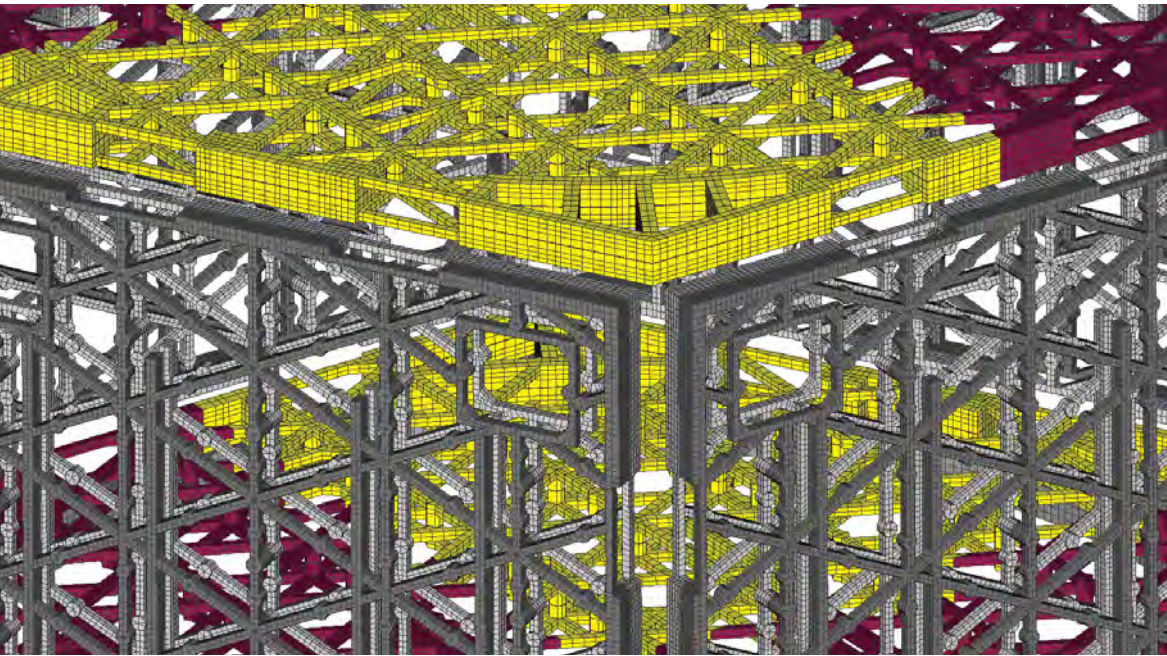

Courtesy of Predictive Engineering

#### NX Nastran analysis capabilities available for Femap

	Femap with NX Nastran	Analysis extensions
<b>Basic analysis capabilities</b>		
Linear static analysis	•	
Normal modes analysis	•	
Buckling analysis	•	
Heat transfer analysis (steady-state and transient)	•	
Basic nonlinear analysis	•	
Connectors and weld elements	•	
Linear contact	•	
Glued connection	•	
Bolt preloads	•	
<b>Advanced analysis capabilities*</b>		
Dynamic response analysis module		•
Advanced nonlinear analysis module		•
Superelements analysis module		•
Direct matrix abstraction programming (DMAP)		•
Design optimization module		•
Topology optimization module		•
Aeroelasticity module		•
Rotor dynamics		•

\* Femap with NX Nastran is a prerequisite for all Advanced add-on modules. Individual product data sheets describing the detailed functionality available in each of the NX Nastran modules are available at [www.siemens.com/plm/femap](http://www.siemens.com/plm/femap)

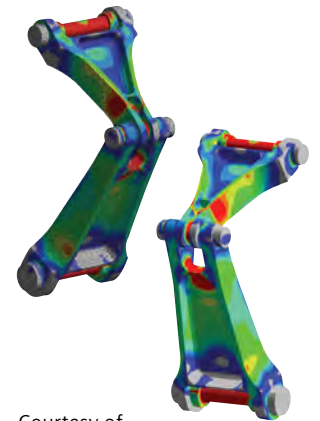

Courtesy of  
Predictive Engineering Inc.



## Integrated multi-physics solvers for Femap

### **Femap Thermal**

Femap Thermal includes both the transient and steady-state thermal analysis capabilities required to solve a majority of common engineering problems. Capabilities include the modeling of conduction, convection, radiation and phase change. Femap Thermal provides a range of thermal boundary conditions and solver controls as well as a powerful thermal modeling tool for assemblies. This thermal coupling capability allows users to create paths for heat to flow between parts in large, complex assemblies.

### **Femap Advanced Thermal**

Femap Advanced Thermal adds many advanced thermal and fluid flow modeling capabilities to the Femap Thermal package. For example, fluid duct flow modeling includes coupled convection and fluid flow analysis. An extensive set of tools for advanced radiation and spacecraft modeling includes solar and orbital heating, orbit modeling and display, specular reflections with ray tracing and articulating structures.

Femap Advanced Thermal also provides advanced solver features such as custom user subroutines, model simplification, substructuring and interfaces to industry thermal codes.



### Femap Flow

Femap Flow provides a comprehensive 3D computational fluid dynamics (CFD) solution fully integrated within Femap. When combined with Femap Advanced Thermal, it solves a wide range of multi-physics problems that involve fluid flow and heat transfer. Both low-speed and high-speed compressible flows can be modeled. The Femap Flow solver uses an efficient and robust element-based finite volume, multi-grid solver to compute 3D fluid velocity, temperature and pressure for both steady-state and transient applications.

Forced flow, natural convection and mixed flows can be modeled with multiple inlets, outlets and internal flow boundary conditions. For electronics cooling applications, the package easily models

fan curves, inlet and outlet resistances as well as convection from thin structures. Rotating systems, moving walls, flow turbulence models, humidity and other features are available for the most advanced fluid flow modeling requirements.

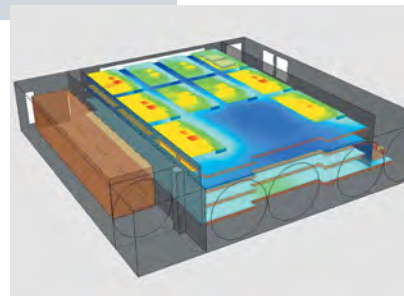
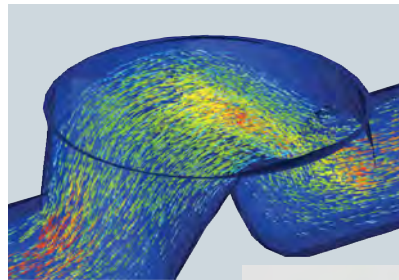

# The Siemens PLM Software advantage

Siemens PLM Software's digital simulation applications are part of a broader portfolio that empowers development teams at the world's largest OEMs as well as thousands of the world's smaller companies. Value depends on the ability of solutions to scale, ensuring the right software is available to the right people and that specialists can leverage the work of the much wider development team.

Throughout its product portfolio, Siemens PLM Software leverages key attributes that help companies achieve business objectives such as waste reduction, quality improvement, shorter cycle times and greater product innovation. These unique attributes directly support business process initiatives aimed at transforming product development:

## Managed development environment

Full integration, synchronized management of all product data and process knowledge to transform product development with a structured collaborative environment.

## Unified product development solution

Seamless integration of applications to rapidly propagate changes of product and process information, replacing point solutions with a unified development system, from concept to manufacturing.

## Knowledge-driven automation

The application of product and process knowledge across all elements of product development to automate processes and maximize re-use.

## Simulation, validation and optimization

Comprehensive simulation and validation tools to automatically check performance and manufacturability at every step of the development process for closed-loop, continuous, repeatable validation.

## System-based modeling

Structured conceptual models standardized design practices that allow rapid creation of variants, transforming development from component-based design to a systems engineering approach.

Courtesy of Evector Aerotechnik

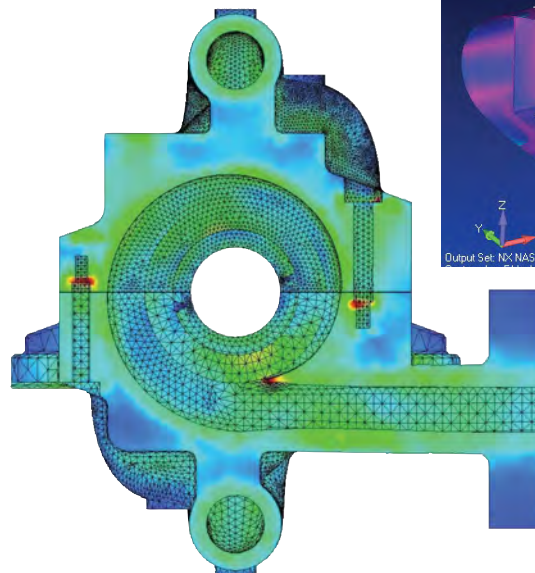
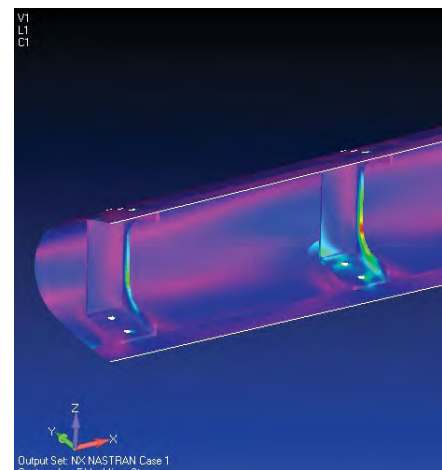
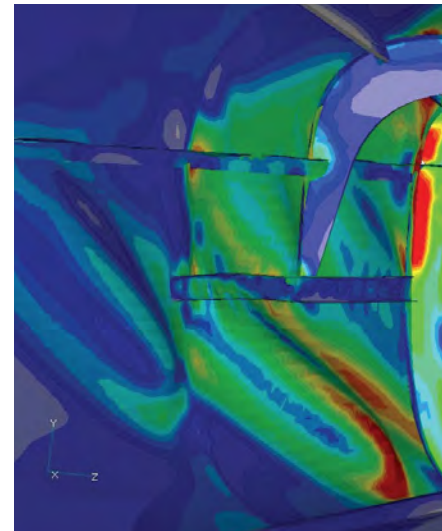

Courtesy of Ruhrpumpen GmbH

Courtesy of Columbia Helicopters Inc.

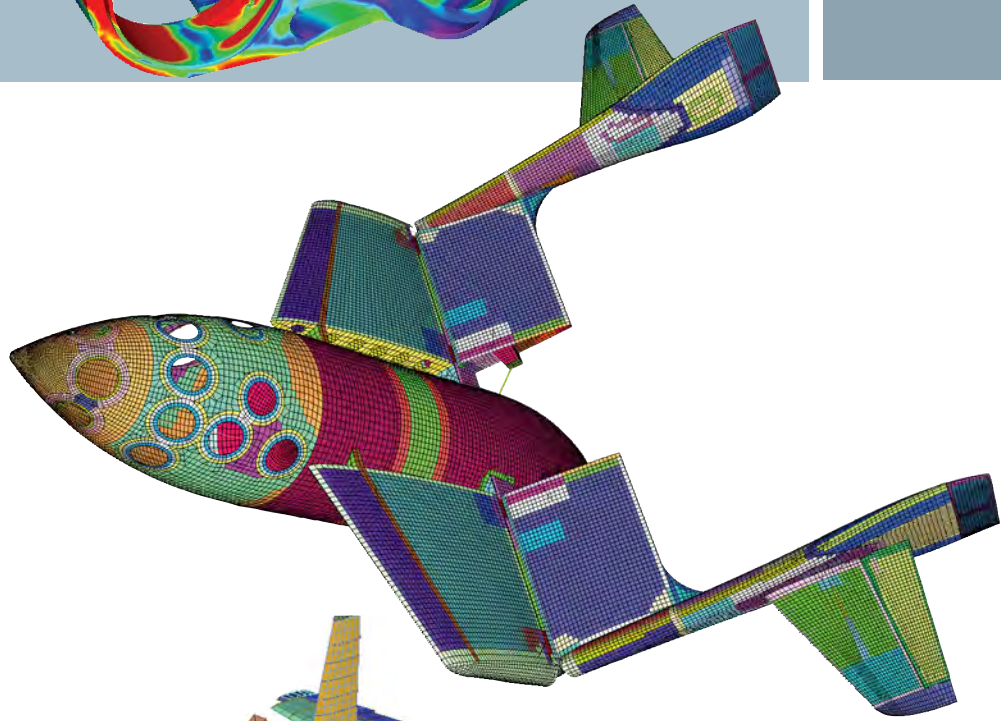
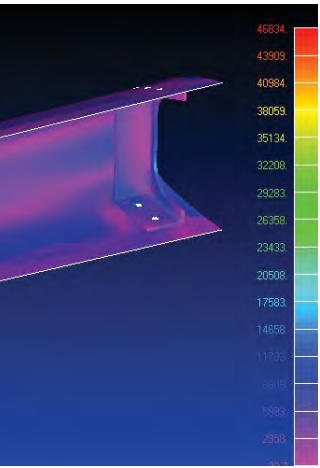
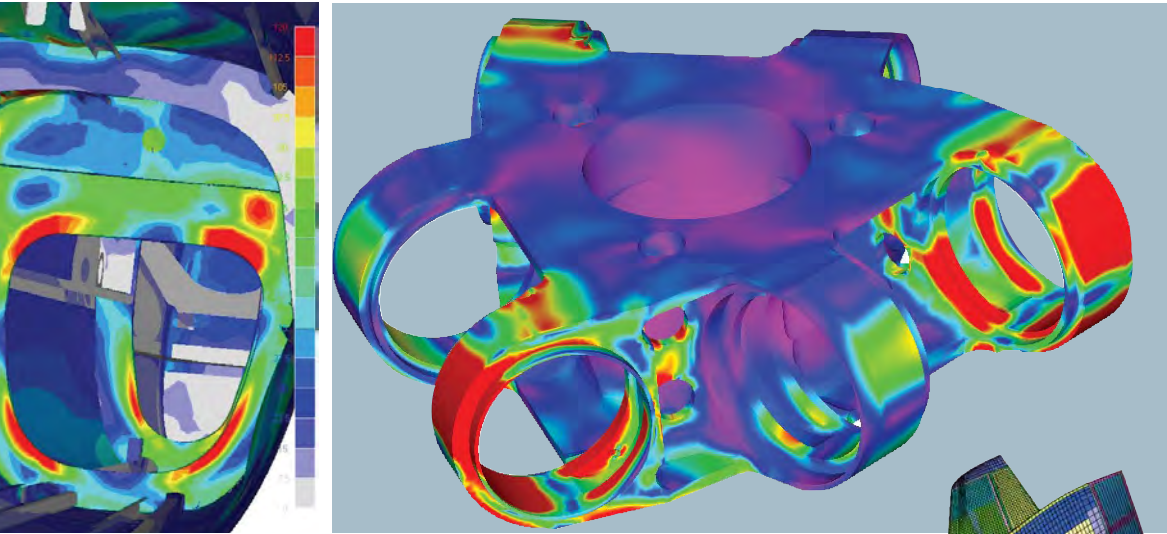

Courtesy of Quartus Engineering Inc.,

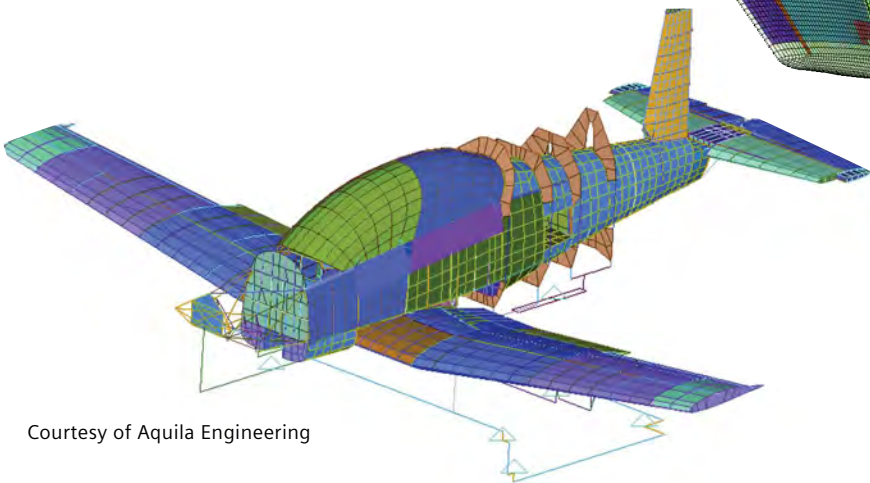

Courtesy of Aquila Engineering

## **Siemens Industry Software**

### **Americas**

+1 800 807 2200

Fax +1 314 264 8922

### **Europe**

+44 (0) 1202 243455

Fax +44 (0) 1202 243465

### **Asia-Pacific**

+852 2230 3308

Fax +852 2230 3210

## **About Siemens PLM Software**

Siemens PLM Software, a business unit of the Siemens Industry Automation Division, is a leading global provider of product lifecycle management (PLM) software and services with 7 million licensed seats and more than 71,000 customers worldwide. Headquartered in Plano, Texas, Siemens PLM Software works collaboratively with companies to deliver open solutions that help them turn more ideas into successful products. For more information on Siemens PLM Software products and services, visit [www.siemens.com/plm](http://www.siemens.com/plm).

© 2011 Siemens Product Lifecycle Management Software Inc. All rights reserved. Siemens and the Siemens logo are registered trademarks of Siemens AG. D-Cubed, Femap, Geolus, GO PLM, I-deas, Insight, JT, NX, Parasolid, Solid Edge, Teamcenter, Tecnomatix and Velocity Series are trademarks or registered trademarks of Siemens Product Lifecycle Management Software Inc. or its subsidiaries in the United States and in other countries. All other logos, trademarks, registered trademarks or service marks used herein are the property of their respective holders.