

Standalone Configuration Control RocketPort board

Shown with a **Control RocketPort** board. This system **does not require** a Network, but **can** be connected to CAD/CAM over a LAN so that each CNC controller can get its' files directly from the CAD/CAM workstation.

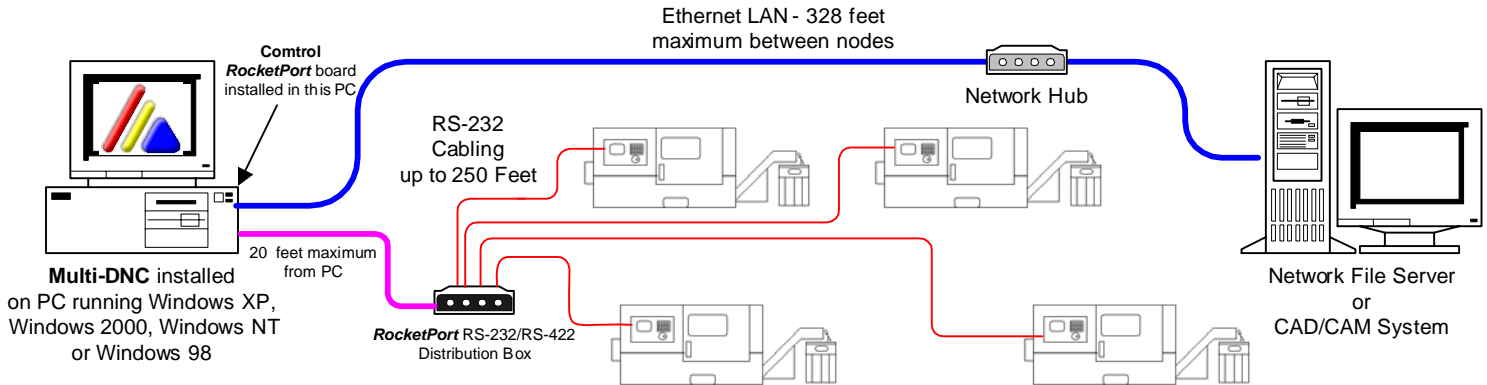

The DNC PC can be on the shop floor, or it can be set up in a cleaner area, depending on what type of RS-232 hardware is used. The Standalone installation is the most common type of **Multi-DNC** system.

Standalone Configuration Control Device Master RTS Hub

Shown with a **Control Device Master RTS Hub**. This system **does require** a Network, and the **Control Hub** is installed in a central location on the shop floor to minimize the RS-232 cabling distance to each CNC Machine. The **Multi-DNC** computer is normally connected to CAD/CAM over a LAN so that each CNC controller can get its' files directly from the CAD/CAM workstation.

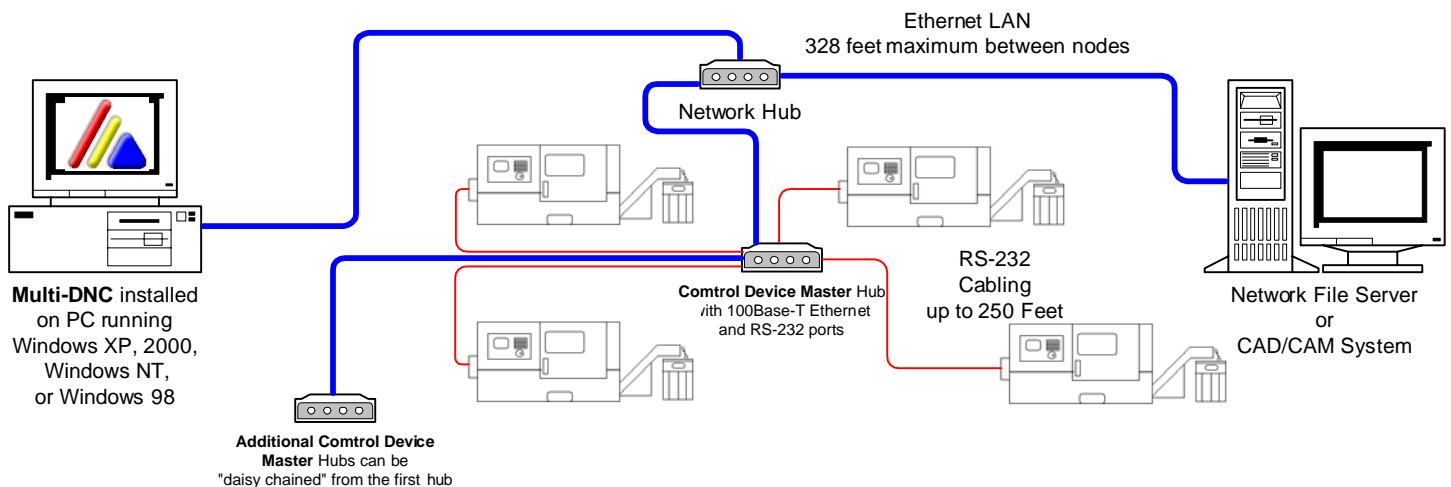

Client-Server Configuration - Requires a LAN, all DNC computers must be using TCP/IP Protocol

What is a Multi-DNC Server ?

A **Multi-DNC Server** is a **Multi-DNC** system with a Server License that is connected to CNC Machine tools by multi-port RS-232 hardware and is also connected to an Ethernet LAN by TCP/IP protocol. Multiple **Multi-DNC Servers** can co-exist on a LAN, and multiple **Multi-DNC Clients** can access them. **Multi-DNC Servers** can run under Windows XP, Windows 2000, Windows NT, or Windows 98 .

What is a Multi-DNC Client ?

A **Multi-DNC Client** is basically the front end interface of **Multi-DNC** connected over a LAN to a **Multi-DNC Server**, but without any direct connections to the CNC controls. **Multi-DNC Clients** can access **Multi-DNC Servers** for Sending, Receiving, initializing or stopping the Remote mode, and can also edit the Machine Connections at the Server computer. A **Multi-DNC Client** can only access one **Multi-DNC Server** at a time, but can log into multiple servers across the LAN.

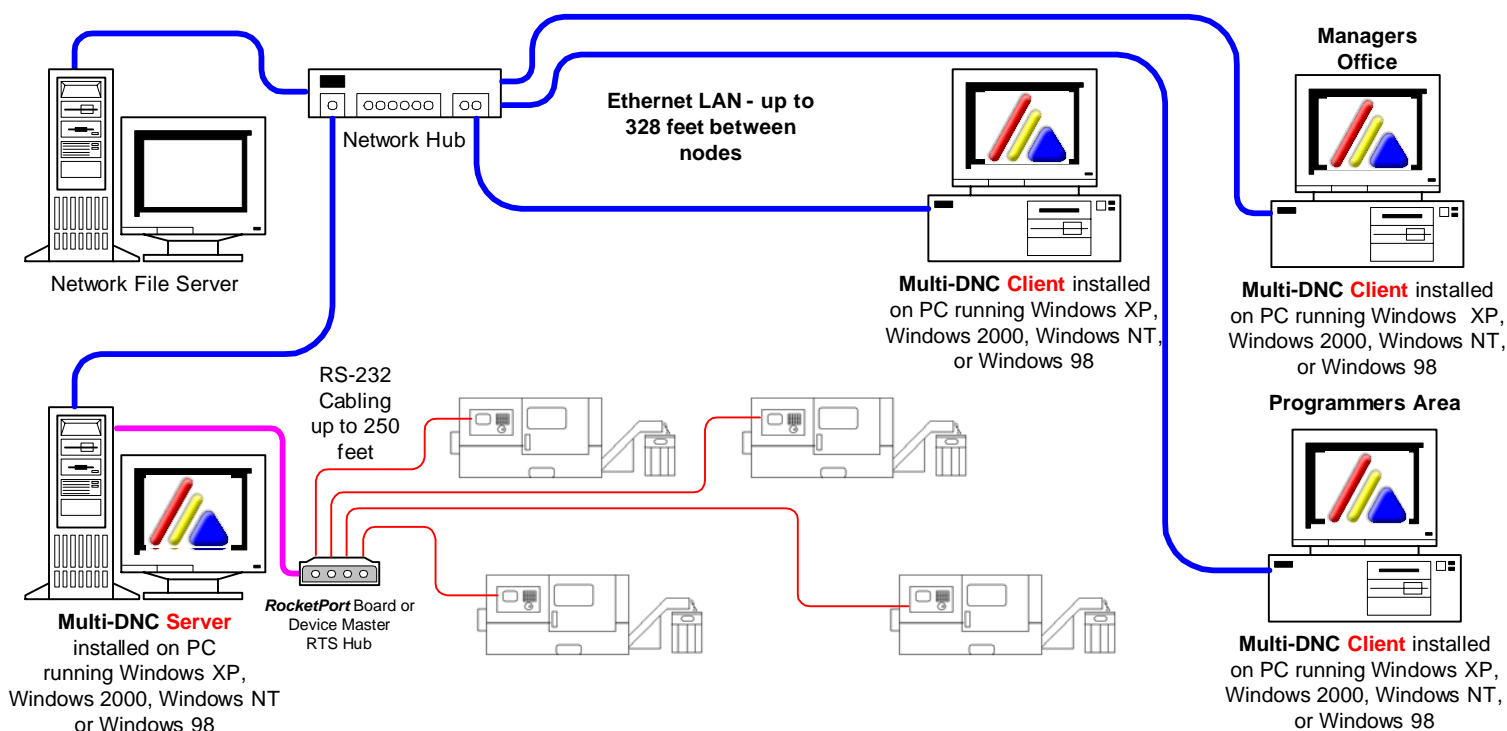

Why use Multi-DNC Client-Server ?

Client-Server allows any connected Client to do 99% of the functions possible from the Server interface itself. Management personnel can just "watch" what is happening at the Server(s) from their connected computers, or actively "make it happen". The Server computer can be put into a more secure area on the manufacturing shop floor, and be administered remotely across the network. **Multi-DNC Clients** can be installed on PC based CAD/CAM workstations so that the CNC programmers can actively initiate sending programs to CNC controls from their programming area.